

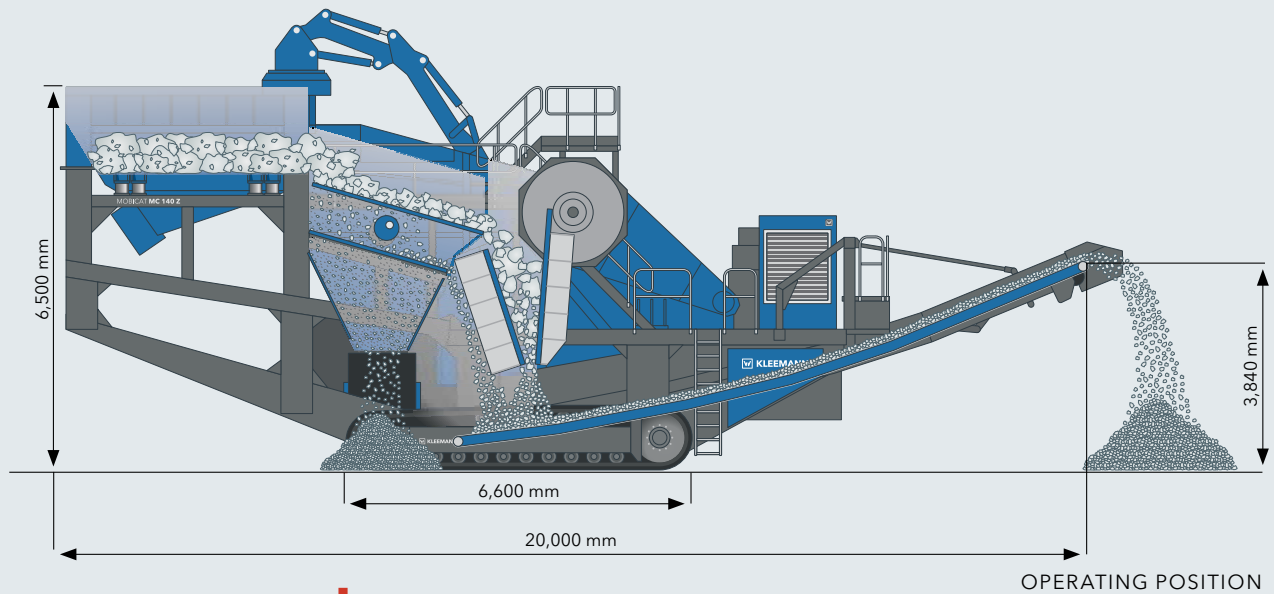

TECHNICAL INFORMATION | TRACK-MOUNTED JAW CRUSHERS

MOBICAT MC 140 Z





TECHNICAL HIGHLIGHTS

- ▣ Frequency-controlled vibrating feeder
- ▣ Independent vibrating double-deck prescreen
- ▣ Option for external power supply (optional)
- ▣ Diesel-electric drive concept

TECHNICAL INFORMATION MC 140 Z

Feeding unit

Feed capacity up to approx. (t/h) ¹⁾	750
Feed size max. (mm)	1,300 x 1,000
Feed height (mm)	6,500
Hopper volume (m ³)	10
Width x Length (mm)	3,700 x 4,600

Vibrating feeder

Width x Length (mm)	1,350 x 4,100
---------------------	---------------

Prescreening

Type	double-deck heavy-piece screen
Width x Length (mm)	1,400 x 3,000

Side discharge conveyor (optional)

Width x Length (mm)	1,000 x 8,000
Discharge height approx. (mm)	4,000

Crusher

Single toggle jaw crusher type	STR 1,400 x 1,130
Crusher inlet width x depth (mm)	1,400 x 1,130
Crusher weight approx. (kg)	54,000
Crusher drive type, approx. (kW)	electric, 200
Adjustment range of gap width (mm) ²⁾	110 - 260
Crusher gap adjustment	hydraulically supported

Crushing capacity ³⁾

with CSS 130 mm: approx. from - to (t/h)	270 - 340
with CSS 160 mm: approx. from - to (t/h)	340 - 420
with CSS 200 mm: approx. from - to (t/h)	430 - 520
with CSS 250 mm: approx. from - to (t/h)	550 - 650

Vibrating feeder (optional)

Width x Length (mm)	1,400 x 2,600
---------------------	---------------

Crusher discharge conveyor

Width x Length (mm)	1,400 x 12,000
Width x Length with vibrating extractor (option) (mm)	1,500 x 10,400
Discharge height approx. (mm)	3,840
Discharge height with vibrating extractor (option) (mm)	4,300

Power supply unit

Drive concept	diesel-electric
Scania (Tier 3 / Stage IIIA) (kW)	438 (1,500 rpm)
Scania (LRC) (kW)	438 (1,500 rpm)
Generator (kVA)	600

Weight

Total weight without options approx. (kg)	160,000
---	---------

¹⁾ dependent on the type and composition of the feed material, the feed size, the prescreening, as well as the desired final grain size

²⁾ gap width range can be changed by using special crusher jaws and/or pressure plates

³⁾ for hard stone, CSS = Close Side Setting

Standard features: Feed hopper / Frequency-controlled vibrating feeder / fill level monitor at crusher inlet / Radio remote control / PLC control with LCD display / Control cabinet, with double dust encapsulation, lockable, suspended and with over pressure system / Lighting

Options: Side discharge conveyor / Electromagnetic separator, permanent magnet, magnet preparation / External power supply / Extended crusher discharge conveyor / Rock chisel / Hydraulic folding device for crusher discharge conveyor / Preparation for installation of belt scale / Belt covers (aluminium, tarpaulin) / Remote maintenance using GSM modem / Socket 110V / Spray system for dust reduction

Volvo Construction Equipment
Building Tomorrow



EC380D, EC480D

Volvo Crawler Excavators 37.8 - 53.1 t 297 - 367 hp



A passion for performance

At Volvo Construction Equipment, we're not just coming along for the ride. Developing products and services that raise productivity – we are confident we can lower costs and increase profits for industry experts. Part of the Volvo Group, we are passionate about innovative solutions to help you work smarter – not harder.

Helping you to do more.

Doing more with less is a trademark of Volvo Construction Equipment. High productivity has long been married to low energy consumption, ease of use and durability. When it comes to lowering life-cycle costs, Volvo is in a class of its own.

Designed to fit your needs.

There is a lot riding on creating solutions that are suited to the particular needs of different industry applications. Innovation often involves high technology – but it doesn't always have to. Some of our best ideas have been simple, based on a clear and deep understanding of our customers' working lives.



You learn a lot in 180 years.

Over the years, Volvo has advanced solutions that have revolutionized the use of construction equipment. No other name speaks Safety louder than Volvo. Protecting operators, those around them and minimizing our environmental impact are traditional values that continue to shape our product design philosophy.

We're on your side.

We back the Volvo brand with the best people. Volvo is truly a global enterprise, one that is on standby to support customers quickly and efficiently – wherever they are.

We have a passion for performance.



Volvo Trucks

Renault Trucks



Mack Trucks



UD Trucks



Volvo Buses



Volvo Construction Equipment



Volvo Penta



Volvo Financial Services



Digging power

Achieve greater digging force and reduced cycle times, particularly when working with hard materials, from increased engine power, pump flow, hydraulic pressure and swing torque.

Powering your productivity

Get productive with Volvo's EC380D and EC480D. Featuring increased engine power and improved hydraulics, these machines perform with greater digging force and shorter cycle times. Sustain optimum power and productivity day in and day out with Volvo.

Improved hydraulics

Quicker cycle times of 8-10%* from improvements in the enhanced hydraulic system which provides more flow to the bucket by using both pumps in conflux, as well as increased total pump flow and smooth combined operation. By simply using gravity, the optional boom float ensures there is more power available to the arm circuit for faster loading cycles and more control for leveling and hammer operation.



Variable width

On the EC480D, mechanical variable width increases the distance between the tracks adding 150mm in width for more stability. An extra 196mm in height protects the underside of the machine from harsh ground conditions. Retracted position allows for easy transportation.



Tractive force

Improved tractive force makes it easy for the machines to climb gradients and travel over rough terrain.

*compared to B-series model

Capitalize on efficiency

Fuel efficiency is at the centre of Volvo's machines. The EC380D and EC480D feature Volvo's new D13 engine, improved hydraulics and our unique ECO mode for superior fuel efficiency. Reduce your fuel consumption, save money and reach new levels of efficiency with Volvo.

ECO mode

Volvo's unique ECO mode features sophisticated electronic pump control technology which improves fuel efficiency by an additional 5%. ECO mode can be used in the G, H and P work modes.

Auto idling system

Reduces rpm to idle when the controls are inactive for a specified time – between 3-20 seconds – which is set via the I-ECU monitor. The system delivers reduced fuel consumption and operating costs.



Engine shut down

The optional auto engine shut down function automatically turns the engine off to reduce fuel consumption when the machine is inactive for five minutes. Operators are informed via the I-ECU monitor before shut down occurs.



Work modes

Volvo's unique system incorporates the work modes within the throttle control for optimum performance. When the operator selects a work mode – I (Idle), F (Fine), G (General), H (Heavy) and P (Power) – the rpm is already set for maximum efficiency.



Fuel efficiency

Volvo's efficient diesel engine, enhanced hydraulic system and well matched components improve fuel efficiency by 8-11%. This ensures more material is moved per litre of fuel for reduced operating costs.



Volvo cab

Volvo's industry-leading cab boasts enhanced visibility from large expanses of glass and slim cab pillars. The spacious environment provides ample storage and leg room. The seat can be adjusted into nine positions for superb operator comfort.

See it all with Volvo

See more and do more from Volvo's spacious cab which provides operators with a superior working environment for reduced fatigue. Featuring built in comfort, all-round visibility and easy to access controls for increased productivity. Step inside and see the results for yourself.

ROPS

An optional Roll Over Protective Structure (ROPS) certified cab is recommended for increased safety in the unlikely event of machine roll over.



Roof hatch

A roof hatch is available as an option for increased air flow and extra visibility when the machine is operating at height.



Climate control

Control your climate with Volvo's powerful, industry-leading automatic climate control and defrosting system. With 14 vents, operators can set their ideal temperature for increased comfort.



Rear view camera

Increase visibility and safety with an optional rear view camera which allows the operator to see the blindspot via the I-ECU monitor.



I-ECU monitor

Large color monitor provides excellent clarity in all light conditions. Using a keypad you can make quick visual and diagnostic checks, increasing uptime and productivity.

It won't let you down

If you're looking for strong and durable performance then look no further. These machines excel in demanding terrain. Featuring reinforced welding and heavy-duty protection, no job is too tough for Volvo's reliable machines – rest assured that the work will get done.

Boom and arm

Reinforced heavy-duty boom and arm built from high strength tensile steel increases reliability in severe applications. Protective strips are welded under the arm. Various boom and arm configurations available.



Protective cover

For increased durability, heavy-duty undercover plates provide additional protection to the underside of the upper and lower frame in tough job site applications, preventing damage from rock and debris.

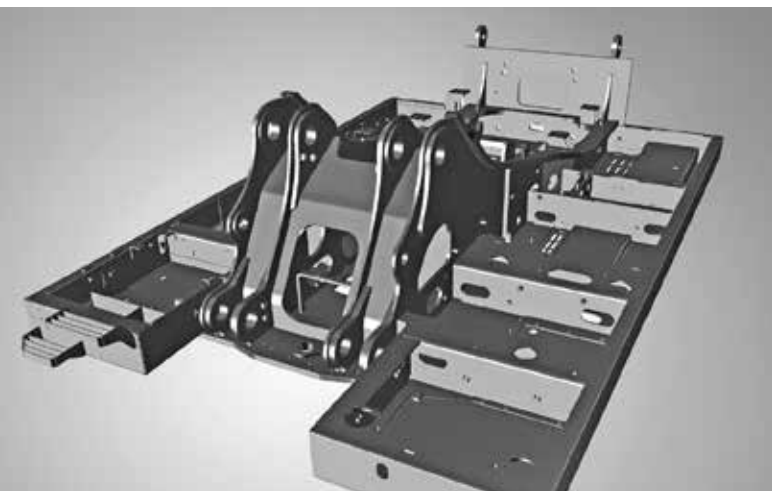

Main frame

The strong and durable structure can easily absorb impacts transferred from the digging equipment. Featuring reinforced welding between the centre and side frames, and the boom and boom cylinder mounts, for increased durability.



Track guard

Optional heavy-duty bolt-on full track roller guards can be fitted for traveling and when working with rock to prevent derailment and protect the bottom rollers and track chain.



Undercarriage

Strong undercarriage featuring a durable fabricated idler, a large diameter roller and a thicker tooth sprocket and track link for increased machine lifetime. The lower frame features additional welding and thicker plating for added protection in demanding terrain.



Serviceability

Grouped filters and greasing points are quick to access from ground level via large, wide compartment doors. Easy access for maintenance means regular checks get done faster, giving you more uptime.

Intelligent serviceability

Volvo machines feature built in serviceability for maximum machine uptime. Benefit from safe and convenient maintenance access and reduced service time. Enjoy maintenance made easy with Volvo.

Oil cooler

Volvo's unique, hydraulic fan-driven oil cooler is separate from the engine and radiator for easier cleaning and servicing – giving you more machine uptime. Independent coolers provide excellent cooling.



Oil return filter

The hydraulic oil return filter boasts excellent filter function and only needs replacing every 2,000 hours – increasing service intervals, reducing operating costs and giving you more machine uptime.



Drains

Access the simple quick drains on the underside of the superstructure without the need for tools. The lubricant won't spill out so you are able to quickly drain it away in an environmentally friendly manner.



Oil bath pre-cleaner

This optional pre-cleaner prevents dirt from entering and damaging the engine for reduced maintenance costs and improved reliability. It is recommended for machines working in dusty environments.

Who says you can't have it all?

Improved hydraulics

Get 8-10%* faster cycle times thanks to improvements in the enhanced hydraulic system.



Fuel efficiency

Volvo's D13 engine, enhanced hydraulic system and well matched components improve fuel efficiency by 8-11%*.



Serviceability

Premium serviceability from large, wide opening doors and grouped, ground level filters and greasing points.

Boom and arm

Reinforced heavy-duty boom and arm built from high strength tensile steel for extra reliability in severe applications.



Digging power

Perform at a higher level with increased digging power and faster cycle times for greater productivity.



*compared to B-series model



Volvo cab

Enjoy all-round visibility and comfort in Volvo's industry-leading cab which features an adjustable seat and ample space.

Climate control

Industry-leading automatic climate control and defrosting system with 14 well-spaced vents for increased comfort.

ECO mode

Volvo's unique ECO mode improves fuel efficiency by an additional 5%.

Oil bath pre-cleaner

Protect your engine and reduce maintenance costs in severely dusty environments with an oil bath pre-cleaner.

Variable width

Mechanical variable width increases the distance between the tracks for extra stability and protection. Retracted position used for transportation.

Oil cooler

Unique oil cooler is separated from the engine and radiator for superior cooling capacity, easier cleaning and servicing.

I-ECU monitor

Large color monitor provides excellent clarity in all light conditions and allows for quick visual and diagnostic checks.



Robust undercarriage

For improved durability and reliability in demanding terrain.

Volvo EC380D, EC480D in detail

Engine		
The Volvo diesel engine delivers lower emissions, superior performance and fuel efficiency. The engine uses precise, high-pressure fuel injectors, turbo charger and intercooler, and electronic engine controls to optimize machine performance.		
Air Filter: 3-stage with precleaner.		
Automatic Idling System: Reduces engine speed to idle when the levers and pedals are not activated resulting in less fuel consumption and low cab noise levels.		

EC380D		
Engine Volvo D13F		
Max power at	r/s / r/min	28 / 1 700
Net (ISO 9249/SAEJ1349)	kW / hp	212 / 288
Gross (ISO 14396/SAE J1995)	kW / hp	219 / 297
Max torque at	Nm / r/min	1580 / 1300
No. of cylinders		6
Displacement	l	12.8
Bore	mm	131
Stroke	mm	158

EC480D		
Engine	Volvo	D13F
Max power at	r/s / r/min	30 / 1800
Net (ISO 9249/SAEJ1349)	kW / hp	261 / 355
Gross (ISO 14396/SAE J1995)	kW / hp	270 / 367
Max torque at	Nm / r/min	1800 / 1400
No. of cylinders		6
Displacement	l	12.8
Bore	mm	131
Stroke	mm	158

	EC380D	EC480D
Electrical system		
High-capacity electrical system that is well protected. Waterproof double-lock harness plugs are used to secure corrosion-free connections. The main relays and solenoid valves are shielded to prevent damage. The master switch is standard. Contronics provides advanced monitoring of machine functions and important diagnostic information.		
Voltage	V	24
Batteries	V	2 x 12
Battery capacity	Ah	200
Alternator	V / Ah	28 / 80

Swing system		
The swing system uses an axial piston motors, driving a planetary gearbox for maximum torque. An automatic holding brake and antirebound valve are standard.		
Max. slew speed	r/min	10.3
Max. slew torque	kNm	130.5

Drive		
Each track is powered by an automatic two-speed shift travel motor. The track brakes are multi-disc, spring-applied and hydraulic released. The travel motor, brake and planetary gears are well protected within the track frame.		
Max. drawbar pull	kN	276
Max. travel speed	km/h	3.4 / 5.3
Gradeability	°	35

Undercarriage		
The undercarriage has a robust X-shaped frame. Greased and sealed track chains are standard.		
Track shoes 2 x 50 2 x 52		
Link pitch	mm	215.9
Shoe width, triple grouser	mm	600/700/800/900
Shoe width, triple grouser (HD)	mm	600
Shoe width, double grouser	mm	600
Bottom rollers		2 x 9
Top rollers		2 x 2

	EC380D	EC480D	
Hydraulic system			
<p>The hydraulic system, also known as the "Automatic Sensing Work Mode", is designed for high-productivity, high-digging capacity, high maneuvering precision and excellent fuel economy. The summation system, boom, arm and swing priority along with boom and arm regeneration provides optimum performance.</p> <p>The following important functions are included in the system:</p> <p>Summation system: Combines the flow of both hydraulic pumps to ensure quick cycle times and high productivity.</p> <p>Boom priority: Gives priority to the boom operation for faster raising when loading or performing deep excavations.</p> <p>Arm priority: Gives priority to the arm operation for faster cycle times in leveling and for increased bucket filling when digging.</p> <p>Swing priority: Gives priority to swing functions for faster simultaneous operations.</p> <p>Regeneration system: Prevents cavitation and provides flow to other movements during simultaneous operations for maximum productivity.</p> <p>Power boost: All digging and lifting forces are increased.</p> <p>Holding valves: Boom and arm holding valves prevent the digging equipment from creeping.</p> <p>Main pump. Type 2 x variable displacement axial piston pumps</p>			
Maximum flow	l/min	2 x 300	2 x 358
Pilot pump. Type Gear pump			
Maximum flow	l/min	1 x 31	1 x 32
Hydraulic motors			
Travel: Variable displacement axial piston motor with mechanical brake			
Slew: Fixed displacement axial piston motor with mechanical brake			
Relief valve setting			
Implement	MPa	32.4 / 35.3	32.4 / 35.3
Travel circuit	MPa	35.3	32.4
Slew circuit	MPa	27.9	25.8
Pilot circuit	MPa	3.9	3.9

	EC380D	EC480D	
Hydraulic cylinders			
Mono boom	2	2	
Bore x Stroke	ø x mm	160 x 1530	165 x 1590
Arm	1	1	
Bore x Stroke	ø x mm	175 x 1750	190 x 1850
Bucket	1	1	
Bore x Stroke	ø x mm	145 x 1285	165 x 1330
ME bucket	1	1	
Bore x Stroke	ø x mm	160 x 1250	175 x 1335
LR Bucket	1	1	
Bore x Stroke	ø x mm	140 x 1140	140 x 1140
Service refill capacities			
Fuel tank	l	620	685
Hydraulic system, total	l	485	520
Hydraulic tank	l	227	270
Engine oil	l	42	42
Engine coolant	l	60	60
Swing reduction unit	l	6.5	2 x 6
Travel reduction unit	l	2 x 6.8	2 x 6
Cab			
<p>The operator's cab has easy access via a wide door opening. The cab is supported on hydraulic dampening mounts to reduce shock and vibration levels. These along with sound absorbing lining provide low noise levels. The cab has excellent all-round visibility. The front windshield can easily slide up into the ceiling, and the lower front glass can be removed and stored in the side door.</p> <p>Integrated air-conditioning and heating system: The pressurized and filtered cab air is supplied by an automatically controlled fan. The air is distributed throughout the cab from 14 vents.</p> <p>Ergonomic operator's seat: The adjustable seat and joystick console move independently to accommodate the operator. The seat has 12 different adjustments plus a seat belt for the operator's comfort and safety.</p>			
Sound Level			
Sound level in cab according to ISO 6396			
LpA	dB(A)	73	73
External sound level according to ISO 6395 and EU Noise Directive (2000/14/EC) and 474-1:2006 +A1:2009			
LwA	dB(A)	106	107

Attachments



Attachment management system

Permits storage of up to 18 + 2 different attachment presets. Enables hydraulic flow (standard) and pressure (optional) adjustments according to requirements. Operator can choose hydraulic settings that are 1-way, 2-way, push button, toggle or proportional (optional). Allows operators to quickly change attachments without the need for manual setup thus saving downtime and increasing productivity. The system can be password protected to prevent possible misuse.



Hydraulic Dedicated Quick Coupler

The hydraulic dedicated quick coupler delivers high breakout force for superior performance. Featuring a tight fit between the coupler and attachment, a light-weight design and compatibility with tiltrotators for ultimate productivity.



Hydraulic Universal Quick Coupler

Easily switch between different buckets without leaving the cab when using a hydraulic universal quick coupler. Buckets can be used in both the face shovel and backhoe position for ultimate versatility.



(GP) General purpose bucket

Designed for digging and re-handling soft to medium materials e.g. soils with low wear characteristics. The GP bucket has anti-abrasive side cutters, a hardened lip plate and self-sharpening bucket teeth.



(HD) Heavy-duty bucket

Intended for digging in dense materials such as hard packed clay and gravel. The HD bucket has heavier overall fabrication with a thicker side cutting edge and hardened plating on all critical ground-engaging areas.



(RK) Rock bucket

Together with harder and thicker plating on all critical leading edges the rock bucket provides digging performance in soils with a high degree of rock content and well blasted rock.



(FD) Fixed ditching bucket

A wide face, round profile and drain holes make the FD bucket ideal for ditch cleaning or removal of other soft material. An inner stiffener and optional bolt-on cutting edge bolster performance.

VOLVO TOOTH SYSTEM



Locking device



GPE



AMRE / ARXE



SNE



Wear Cap and BLW Adapter

Self-Sharpening Tooth System Cuts Through the Toughest Jobs

Volvo perfects the excavator bucket's point of attack with a robust tooth system that delivers performance and long life. Cast and tempered from a high-strength alloy, Volvo teeth resist stress and deliver optimum penetration in hard or abrasive material. An innovative design lessens internal wear between tooth and adapter — and makes it easy to change teeth.

Locking device

Patented vertical locking device. The steel pin with flexible lock retainer tightly secures the tooth to the adapter. Smart design transfers working stresses away from the locking device, saving wear on the steel pin and extending pin life. Self-sharpening Volvo teeth are designed for a small penetration area, which reduces stress and wear at the point of contact.

GPE

Self-sharpening general-purpose tooth with good penetration and long service life.

AMRE / ARXE

Tooth with extra-wear metal and longer service life intended for rock and abrasive material. Self sharpening.

SNE

Spade nose tooth is designed for finishing work such as leveling, grading, cleaning and backfilling.

Wear Cap and BLW Adapter

The wear cap protects the adapter from unnecessary wear.

BLW: Bottom leg adapter for wear cap with extra long top leg for welding to both sides of the cutting edge. Long bottom leg.

BL: 11/2 bottom leg adapter for welding to both sides of the cutting edge.

MAXIMUM PERMITTED BUCKETS

Direct fit Buckets		EC380DL with 7 000 kg counterweight				EC480DL* with 9 050 kg counterweight						EC480DL** with 9 750 kg counterweight							
Boom	m	6.45			6.2	7.0					6.5		7.0					6.5	
Arm	m	2.6	3.2	3.9	2.6	2.55	3.0	3.35	3.9	4.8	2.55	3.0	2.55	3.0	3.35	3.9	4.8	2.55	3.0
Max. Bucket	t/m ³	liter	liter	liter	liter	liter	liter	liter	liter	liter	liter	liter	liter	liter	liter	liter	liter	liter	liter
GP Bucket	1.5 t/m ³	2 775	2 550	2 300	2 775	3 425	3 275	3 125	2 850	2 525	3 725	3 575	3 625	3 450	3 300	3 025	2 675	3 950	3 775
GP Bucket	1.8 t/m ³	2 450	2 250	2 050	2 450	3 000	2 875	2 725	2 500	2 225	3 275	3 125	3 175	3 025	2 875	2 650	2 350	3 450	3 300
HD Bucket	1.8 t/m ³	2 325	2 125	1 925	2 325	2 775	2 650	2 525	2 300	2 050	3 000	2 900	2 925	2 800	2 650	2 425	2 150	3 175	3 050
HD Bucket	2.0 t/m ³	2 175	2 000	1 800	2 175	2 575	2 450	2 325	2 150	1 900	2 800	2 675	2 700	2 600	2 475	2 250	2 000	2 950	2 825

S quick fit Buckets		EC380DL with 7 000 kg counterweight				EC480DL* with 9 050 kg counterweight						EC480DL** with 9 750 kg counterweight							
Boom	m	6.45			6.2	7.0					6.5		7.0					6.5	
Arm	m	2.6	3.2	3.9	2.6	2.55	3.0	3.35	3.9	4.8	2.55	3.0	2.55	3.0	3.35	3.9	4.8	2.55	3.0
Max. Bucket	t/m ³	liter	liter	liter	liter	liter	liter	liter	liter	liter	liter	liter	liter	liter	liter	liter	liter	liter	liter
GP Bucket	1.5 t/m ³	2 600	2 350	2 125	2 600	3 300	3 150	2 975	2 725	2 400	3 600	3 450	3 475	3 325	3 150	2 875	2 550	3 800	3 650
GP Bucket	1.8 t/m ³	2 300	2 100	1 875	2 300	2 875	2 750	2 600	2 375	2 100	3 150	3 025	3 050	2 900	2 750	2 525	2 225	3 325	3 175
HD Bucket	1.8 t/m ³	2 175	1 975	1 775	2 175	2 650	2 525	2 400	2 200	1 925	2 900	2 775	2 800	2 675	2 550	2 325	2 050	3 075	2 950
HD Bucket	2.0 t/m ³	2 025	1 850	1 675	2 025	2 475	2 350	2 225	2 050	1 800	2 700	2 575	2 600	2 475	2 375	2 150	1 900	2 850	2 725

U quick fit Buckets		EC380DL with 7 000 kg counterweight				EC480DL* with 9 050 kg counterweight						EC480DL** with 9 750 kg counterweight							
Boom	m	6.45			6.2	7.0					6.5		7.0					6.5	
Arm	m	2.6	3.2	3.9	2.6	2.55	3.0	3.35	3.9	4.8	2.55	3.0	2.55	3.0	3.35	3.9	4.8	2.55	3.0
Max. Bucket	t/m ³	liter	liter	liter	liter	liter	liter	liter	liter	liter	liter	liter	liter	liter	liter	liter	liter	liter	liter
GP Bucket	1.5 t/m ³	2 425	2 200	1 950	2 425	3 125	2 975	2 800	2 550	2 225	3 425	3 275	3 300	3 150	2 975	2 700	2 350	3 625	3 475
GP Bucket	1.8 t/m ³	2 150	1 950	1 725	2 150	2 725	2 600	2 450	2 225	1 950	3 000	2 850	2 900	2 750	2 600	2 375	2 075	3 175	3 025
HD Bucket	1.8 t/m ³	2 025	1 825	1 650	2 025	2 525	2 400	2 275	2 050	1 800	2 750	2 650	2 675	2 525	2 400	2 175	1 900	2 925	2 800
HD Bucket	2.0 t/m ³	1 900	1 700	1 525	1 900	2 325	2 225	2 100	1 900	1 675	2 550	2 450	2 475	2 350	2 225	2 025	1 775	2 725	2 600

Note: 1. Bucket size based on ISO 7451, heaped material with a 1:1 angle of repose.
 2. "Max. permitted sizes" are for reference only and are not necessarily available from the factory.
 3. Bucket widths are less than bucket's tip radius.

* FIXED UNDERCARRIAGE

** RETRACTABLE UNDERCARRIAGE

Specifications

MACHINE WEIGHTS AND GROUND PRESSURE

		EC380DL				EC480DL				EC480DL			
Boom	m	6.45				6.45				8.5			
Arm	m	2.6				2.6				5.0			
Bucket	kg	1 752				1 752				1 090			
Counterweight	kg	6 500				7 000				8 500			
		Shoe width	Operating weight	Ground pressure	Overall width	Shoe width	Operating weight	Ground pressure	Overall width	Shoe width	Operating weight	Ground pressure	Overall width
		mm	kg	kPa	mm	mm	kg	kPa	mm	mm	kg	kPa	mm
Triple grouser		600	37 840	68.6	3 340	600	38 340	69.5	3 340	600	40 980	74.3	3 340
		HD 600	38 117	69.1	3 340	HD 600	38 617	70.0	3 340	HD 600	41 257	74.8	3 340
		700	38 330	59.8	3 440	700	38 830	60.6	3 440	700	41 470	64.7	3 440
		800	38 760	53.0	3 540	800	39 260	53.7	3 540	800	41 410	56.6	3 540
		900	39 200	48.1	3 640	900	39 700	48.7	3 640	900	41 420	50.8	3 640
Double grouser		600	38 000	69.6	3 340	600	38 500	70.5	3 340	-	-	-	-

		EC380DL				EC480DL				EC480DL			
Boom	m	6.45				6.45				8.5			
Arm	m	2.6				2.6				5.0			
Bucket	kg	1 752				1 752				1 090			
Counterweight	kg	6 500				7 000				8 500			
		Shoe width	Operating weight	Ground pressure	Overall width	Shoe width	Operating weight	Ground pressure	Overall width	Shoe width	Operating weight	Ground pressure	Overall width
		mm	kg	kPa	mm	mm	kg	kPa	mm	mm	kg	kPa	mm
Triple grouser		600	47 300	82.4	3 340	600	47 900	83.4	3 340	600	50 510	87.9	3 340
		700	47 800	71.7	3 440	700	48 400	72.6	3 440	700	51 010	76.5	3 440
		800	48 300	62.9	3 540	800	48 900	63.7	3 540	800	51 510	67.1	3 540
		900	48 900	57.2	3 640	900	49 500	57.9	3 640	900	52 110	61.0	3 640
Double grouser		600	47 400	82.4	3 340	600	48 000	83.4	3 340	-	-	-	-

		EC380DL				EC480DL				EC480DL			
Boom	m	6.45				6.45				8.5			
Arm	m	2.6				2.6				5.0			
Bucket	kg	1 752				1 752				1 090			
Counterweight	kg	6 500				7 000				8 500			
		Shoe width	Operating weight	Ground pressure	Overall width	Shoe width	Operating weight	Ground pressure	Overall width	Shoe width	Operating weight	Ground pressure	Overall width
		mm	kg	kPa	mm	mm	kg	kPa	mm	mm	kg	kPa	mm
Triple grouser		600	49 000	85.3	3 490	600	49 700	86.5	3 490	600	51 610	89.8	3 340
		700	49 500	73.5	3 590	700	50 200	74.5	3 590	700	52 110	77.4	3 440
		800	50 000	65.7	3 690	800	50 700	66.6	3 690	800	52 610	69.1	3 540
		900	50 500	58.8	3 790	900	51 200	59.6	3 790	900	53 110	61.8	3 640
Double grouser		600	49 100	85.3	3 490	600	49 800	86.5	3 490	-	-	-	-

* FIXED UNDERCARRIAGE ** RETRACTABLE UNDERCARRIAGE

DIMENSIONS

Boom

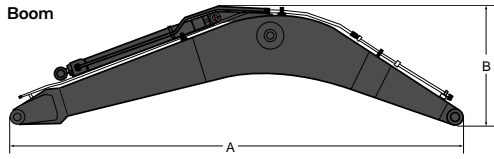

Arm

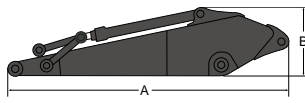

	EC380DL			EC480DL			
			long reach			long reach	
Boom	m	6.2	6.45	8.5	6.5	7.0	9.0
A. Length	mm	6460	6700	8750	6750	7250	9270
B. Height	mm	1740	1800	1910	2000	1840	1950
Width	mm	820	820	820	960	960	960
Weight	kg	3530	3550	4856	4300	4380	6080

	EC380DL				EC480DL						
				long reach							long reach
Arm	m	2.6	3.2	3.9	5.0	2.55	3.0	3.35	3.9	4.8	6.0
A. Length	mm	3780	4360	5080	6180	3770	4260	4590	5140	6100	7200
B. Height	mm	1150	1150	1150	1040	1270	1270	1270	1270	1270	1180
Width	mm	560	560	560	560	600	600	600	600	600	560
Weight	kg	2050	2220	2300	2527	2340	2630	2630	2590	2730	3163

Includes arm cylinder, piping and pin

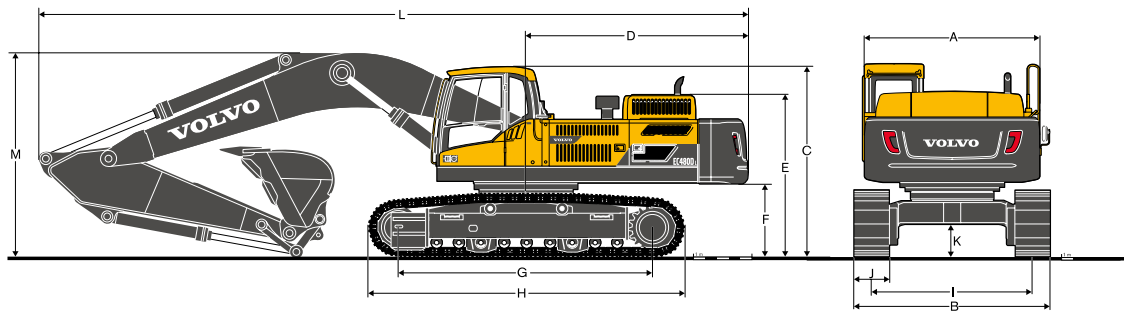

Description		EC380DL				EC480DL*						
Boom	m	6.2	6.45			6.5	7.0					
Arm	m	2.6	2.6	3.2	3.9	2.55	3.0	2.55	3.0	3.35	3.9	4.8
A. Overall width of upper structure	mm	2 990	2 990	2 990	2 990	2 990	2 990	2 990	2 990	2 990	2 990	2 990
B. Overall width	mm	3 340	3 340	3 340	3 340	3 440	3 440	3 440	3 440	3 440	3 440	3 440
C. Overall height of cab	mm	3 197	3 197	3 197	3 197	3 257	3 257	3 257	3 257	3 257	3 257	3 257
D. Tail slew radius	mm	3 560	3 560	3 560	3 560	3 800	3 800	3 800	3 800	3 800	3 800	3 800
E. Overall height of engine hood	mm	2 720	2 720	2 720	2 720	2 770	2 770	2 770	2 770	2 770	2 770	2 770
F†. Counterweight clearance	mm	1 210	1 210	1 210	1 210	1 275	1 275	1 275	1 275	1 275	1 275	1 275
G. Tumbler length	mm	4 240	4 240	4 240	4 240	4 370	4 370	4 370	4 370	4 370	4 370	4 370
H. Track length	mm	5 180	5 180	5 180	5 180	5 370	5 370	5 370	5 370	5 370	5 370	5 370
I. Track gauge	mm	2 740	2 740	2 740	2 740	2 740	2 740	2 740	2 740	2 740	2 740	2 740
J. Shoe width	mm	600	600	600	600	700	700	700	700	700	700	700
K†. Min. ground clearance	mm	500	500	500	500	550	550	550	550	550	550	550
L. Overall length	mm	11 080	11 330	11 240	11 290	11 630	11 590	12 130	12 100	12 140	12 140	12 010
M. Overall height of boom	mm	3 700	3 580	3 350	3 590	3 770	3 810	3 630	3 680	3 650	3 690	4 650

Description		EC480DL**							EC380DLR	EC480DLR*	EC480DLR**
Boom	m	6.5		7.0					8.5	9.0	9.0
Arm	m	2.55	3.0	2.55	3.0	3.35	3.9	4.8	5.0	6.0	6.0
A. Overall width of upper structure	mm	2 990	2 990	2 990	2 990	2 990	2 990	2 990	2 990	2 990	2 990
B. Overall width	mm	3 590	3 590	3 590	3 590	3 590	3 590	3 590	3 340	3 440	3 590
Overall width (retracted)	mm	3 090	3 090	3 090	3 090	3 090	3 090	3 090	-	-	3 090
C. Overall height of cab	mm	3 370	3 370	3 370	3 370	3 370	3 370	3 370	3 197	3 257	3 370
D. Tail slew radius	mm	3 800	3 800	3 800	3 800	3 800	3 800	3 800	3560	3 800	3 800
E. Overall height of engine hood	mm	2 880	2 880	2 880	2 880	2 880	2 880	2 880	2 720	2 770	2 880
F†. Counterweight clearance	mm	1 385	1 385	1 385	1 385	1 385	1 385	1 385	1 210	1 275	1 385
G. Tumbler length	mm	4 370	4 370	4 370	4 370	4 370	4 370	4 370	4 240	4 370	4 370
H. Track length	mm	5 370	5 370	5 370	5 370	5 370	5 370	5 370	5180	5 370	5 370
I. Track gauge	mm	2 390	2 390	2 390	2 390	2 390	2 390	2 390	2 740	2 740	2 390
Track gauge (extended)	mm	2 890	2 890	2 890	2 890	2 890	2 890	2 890	-	-	2 890
J. Shoe width	mm	700	700	700	700	700	700	700	600	700	700
K†. Min. ground clearance	mm	746	746	746	746	746	746	746	500	550	749
L. Overall length	mm	11 630	11 590	12 130	12 100	12 140	12 140	12 010	13 080	13 620	13 620
M. Overall height of boom	mm	3 800	3 810	3 630	3 680	3 650	3 830	4 790	4 480	5 630	5 770

† Without shoe grouser * FIXED UNDERCARRIAGE ** RETRACTABLE UNDERCARRIAGE

Specifications

WORKING RANGES

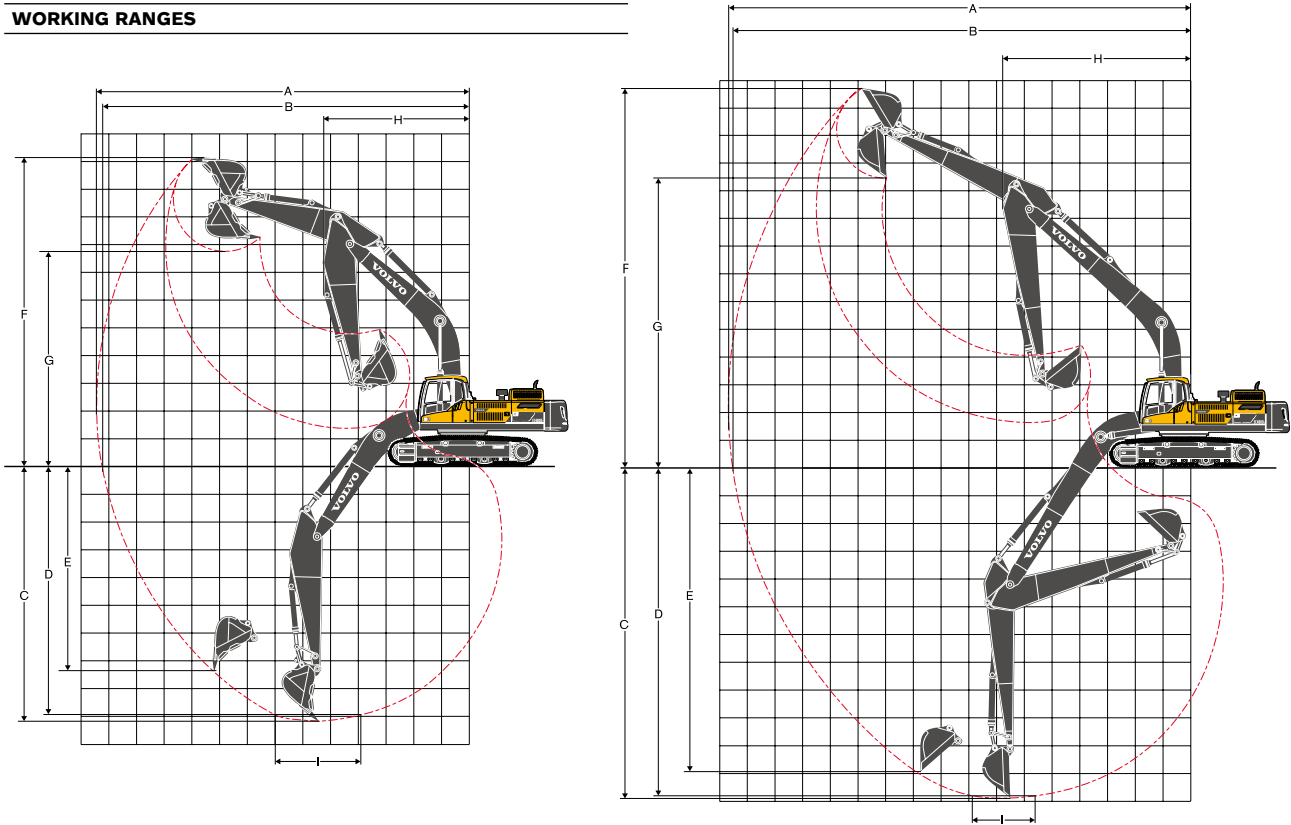

Description		EC380DL				EC480DL*							
Boom	m	6.2	6.45			6.5		7.0					
Arm	m	2.6	2.6	3.2	3.9	2.55	3.0	2.55	3.0	3.35	3.9	4.8	
A. Max. digging reach	mm	10 430	10 550	11 070	11 720	10 930	11 290	11 340	11 710	12 040	12 530	13 260	
B. Max. digging reach on ground	mm	10 210	10 330	10 860	11 520	10 680	11 050	11 110	11 480	11 810	12 320	13 060	
C. Max. digging depth	mm	740	6 850	7 450	8 150	6 580	7 030	6 920	7 370	7 720	8 270	9 170	
D. Max. digging depth (l. 2.44 m level)	mm	6 550	6 640	7 270	8 000	6 410	6 880	6 750	7 210	7 570	8 140	9 050	
E. Max. vertical wall digging depth	mm	4 970	5 350	5 790	6 410	5 990	6 430	6 270	6 670	7 110	7 570	8 020	
F. Max. cutting height	mm	10 070	10 170	10 340	10 600	10 600	10 590	10 860	10 860	11 020	11 190	11 130	
G. Max. dumping height	mm	6 820	7 090	7 290	7 560	6 970	7 020	7 420	7 480	7 640	7 820	7 850	
H. Min. front swing radius	mm	4 120	4 320	4 280	4 310	4 780	4 740	5 170	5 130	5 090	5 050	5 100	
Digging forces with direct fit bucket													
Bucket radius	mm	1 810	1 623	1 623	1 623	1 923	1 923	1 810	1 810	1 810	1 810	1 810	
Breakout force – bucket	Normal	SAE J1179	kN	215	198	198	198	253	253	230	230	230	230
	Power boost	SAE J1179	kN	235	215	215	215	275	275	251	251	251	251
	Normal	ISO 6015	kN	243	222	222	222	285	285	261	261	261	261
	Power boost	ISO 6015	kN	265	243	243	243	311	311	284	284	284	284
Tearout force – dipper arm	Normal	SAE J1179	kN	188	196	162	141	225	205	232	211	196	176
	Power boost	SAE J1179	kN	206	213	177	154	244	224	252	230	215	192
	Normal	ISO 6015	kN	194	201	166	144	232	212	239	216	201	179
	Power boost	ISO 6015	kN	212	219	181	157	253	231	260	235	220	196
Rotation angle, bucket	°	164	177	177	177	169	169	183	183	183	183	183	

WORKING RANGES

Description		EC480DL**							EC380DLR	EC480DLR*	EC480DLR**	
Boom	m	6.5		7.0					8.5	9.0	9.0	
Arm	m	2.55	3.0	2.55	3.0	3.35	3.9	4.8	5.0	6.0	6.0	
A. Max. digging reach	mm	10 930	11 290	11 340	11 710	12 040	12 530	13 260	14 750	16 460	16 460	
B. Max. digging reach on ground	mm	10 660	11 030	11 090	11 460	11 790	12 300	13 040	14 590	16 300	16 280	
C. Max. digging depth	mm	6 470	6 920	6 810	7 260	7 610	8 160	9 060	10 980	11 870	11 760	
D. Max. digging depth (l. 2.44 m level)	mm	6 300	6 770	6 640	7 100	7 460	8 030	8 940	10 860	11 770	11 660	
E. Max. vertical wall digging depth	mm	5 880	6 320	6 160	6 560	7 000	7 460	7 910	10 370	11 240	11 130	
F. Max. cutting height	mm	10 710	10 700	10 970	10 970	11 130	11 300	11 240	12 610	13 750	13 860	
G. Max. dumping height	mm	7 080	7 130	7 530	7 590	7 750	7 930	7 960	9 610	10 700	10 810	
H. Min. front swing radius	mm	4 780	4 740	5 170	5 130	5 090	5 050	5 100	5 730	6 610	6 610	
Digging forces with direct fit bucket												
Bucket radius	mm	1 923	1 923	1 810	1 810	1 810	1 810	1 810	1 598	1 598	1 598	
Breakout force – bucket	Normal SAE J1179	kN	253	253	230	230	230	230	230	148	163	163
	Power boost SAE J1179	kN	275	275	251	251	251	251	251	148	178	178
	Normal ISO 6015	kN	285	285	261	261	261	261	261	166	183	183
	Power boost ISO 6015	kN	311	311	284	284	284	284	284	166	200	200
Tearout force – dipper arm	Normal SAE J1179	kN	225	205	232	211	196	176	160	120	130	130
	Power boost SAE J1179	kN	244	224	252	230	215	192	174	131	142	142
	Normal ISO 6015	kN	232	212	239	216	201	179	163	122	132	132
	Power boost ISO 6015	kN	253	231	260	235	220	196	178	133	144	144
Rotation angle, bucket	°	169	169	183	183	183	183	183	177	177	177	

* FIXED UNDERCARRIAGE, Machine with pin-on bucket

** RETRACTABLE UNDERCARRIAGE, Machine with pin-on bucket

Bucket spec. for Working Range

EC380D

- For ME Boom : VGP50 2 300 L VTS (Bucket tip radius : 1 826.34 mm)

- For STD Boom : KGP36 1 610 L KTS (Bucket tip radius : 1 697.23 mm)

- For LR Boom : KGP29 1 400 L KTS (Bucket tip radius : 1 598.3 mm)

EC480D

- For ME Boom : VGP60 2 600 L VTS (Bucket tip radius : 1 948.40 mm)

- For STD Boom : KGP46 2 060 L KTS (Bucket tip radius : 1 847.01 mm)

- For LR Boom : KGP29 1 600 L KTS (Bucket tip radius : 1 598.3 mm)

Specifications

EXPLANATION OF LIFTING CAPACITY TABLES

Example: EC380DL

Lifting capacity at the arm end without bucket.

For lifting capacity including bucket, simply subtract actual weight of the direct fit bucket or the bucket with quick coupler from the following values.

	Lifting hook related to ground level	1.5 m		3.0 m		4.5 m		6.0 m		7.5 m		9.0 m		Max. reach		mm	
		Along UC	Across UC	Along UC	Across UC	Along UC	Across UC	Along UC	Across UC	Along UC	Across UC	Along UC	Across UC	Along UC	Across UC		
Boom: 6.2 m	7.5 m kg	-	-	-	-	-	-	*10 730	9 890	-	-	-	-	*10 940	8 140	6 717	
	6.0 m kg	-	-	-	-	-	-	*11 270	9 690	*10 800	6 730	-	-	10 530	6 430	7 694	
	4.5 m kg	-	-	-	-	*15 950	14 330	*12 740	9 270	10 850	6 580	-	-	9 200	5 580	8 288	
	Arm: 2.6 m	3.0 m kg	-	-	-	-	*19 950	13 190	*14 580	8 780	10 590	6 340	-	-	8 570	5 160	8 579
	Shoe: 600 mm	1.5 m kg	-	-	-	-	*22 520	12 470	14 570	8 370	10 340	6 130	-	-	8 420	5 030	8 600
	0 m kg	-	-	-	-	*23 070	12 230	14 290	8 130	10 180	5 990	-	-	8 720	5 170	8 351	
	CWT: 7050 kg	-1.5 m kg	-	-	*17 930	*17 930	*22 250	12 240	14 220	8 080	10 170	5 970	-	-	9 610	5 680	7 807
	-3.0 m kg	-	-	*26 840	24 630	*20 070	12 440	14 370	8 200	-	-	-	-	11 660	6 830	6 898	
	-4.5 m kg	-	-	-	-	*15 500	12 900	-	-	-	-	-	-	*12 300	9 850	5 439	

Notes: 1. Machine in "Fine Mode-F" (Power Boost) for lifting capacities.

2. The above loads are in compliance with SAE J1097 and ISO 10567 Hydraulic Excavator Lifting Capacity Standards.

3. Rated loads do not exceed 87% of hydraulic lifting capacity or 75% of tipping load.

4. Rated loads marked with an asterisk (*) are limited by hydraulic capacity rather than tipping load.

LIFTING CAPACITY EC380DL

		1.5 m		3.0 m		4.5 m		6.0 m		7.5 m		9.0 m		Max. reach		mm	
		Along UC	Across UC	Along UC	Across UC	Along UC	Across UC	Along UC	Across UC	Along UC	Across UC	Along UC	Across UC	Along UC	Across UC		
Boom: 6.2 m	7.5 m kg	-	-	-	-	-	-	*10 730	*10 730	-	-	-	-	*10 940	9 120	6 717	
	6.0 m kg	-	-	-	-	-	-	*11 270	10 890	*10 800	7 540	-	-	*10 620	7 210	7 694	
	4.5 m kg	-	-	-	-	*15 950	*15 950	*12 740	10 460	*11 260	7 380	-	-	9 740	6 260	8 288	
	Arm: 2.6 m	3.0 m kg	-	-	-	-	*19 950	15 200	*14 580	9 940	11 230	7 150	-	-	9 080	5 810	8 579
	Shoe: 600 mm	1.5 m kg	-	-	-	-	*22 520	14 440	15 580	9 520	10 980	6 920	-	-	8 920	5 670	8 600
	0 m kg	-	-	-	-	*23 070	14 180	15 290	9 270	10 820	6 780	-	-	9 240	5 850	8 351	
	CWT: 6500 kg	-1.5 m kg	-	-	*17 930	*17 930	*22 250	14 190	15 220	9 210	10 810	6 760	-	-	10 210	6 420	7 807
	-3.0 m kg	-	-	*26 840	*26 840	*20 070	14 400	*15 200	9 340	-	-	-	-	12 420	7 740	6 898	
	-4.5 m kg	-	-	-	-	*15 500	14 890	-	-	-	-	-	-	*12 300	11 230	5 439	
Boom: 6.45 m	7.5 m kg	-	-	-	-	-	-	-	-	-	-	-	-	*10 440	8 450	7 031	
	6.0 m kg	-	-	-	-	-	-	*11 010	10 840	*10 360	7 530	-	-	*10 380	6 780	7 969	
	4.5 m kg	-	-	-	-	*16 120	*16 120	*12 600	10 360	*10 980	7 340	-	-	9 240	5 930	8 543	
	Arm: 2.6 m	3.0 m kg	-	-	-	-	-	-	*14 480	9 820	11 160	7 080	-	-	8 640	5 510	8 826
	Shoe: 600 mm	1.5 m kg	-	-	-	-	-	-	15 430	9 380	10 900	6 840	-	-	8 490	5 380	8 846
	0 m kg	-	-	-	-	*22 070	14 000	15 150	9 150	10 730	6 690	-	-	8 770	5 530	8 605	
	CWT: 6500 kg	-1.5 m kg	-	-	*14 980	*14 980	*22 050	14 030	15 080	9 090	10 690	6 660	-	-	9 620	6 040	8 079
	-3.0 m kg	-	-	*26 560	*26 560	*20 090	14 240	15 220	9 210	-	-	-	-	11 520	7 180	7 204	
	-4.5 m kg	-	-	*21 140	*21 140	*16 190	14 680	-	-	-	-	-	-	*12 080	10 010	5 824	
Boom: 6.45 m	7.5 m kg	-	-	-	-	-	-	-	-	*8 870	7 760	-	-	*7 750	7 470	7 663	
	6.0 m kg	-	-	-	-	-	-	-	-	*9 530	7 690	-	-	*7 540	6 160	8 531	
	4.5 m kg	-	-	-	-	*14 390	*14 390	*11 650	10 580	*10 300	7 460	*8 320	5 530	*7 610	5 460	9 069	
	Arm: 3.2 m	3.0 m kg	-	-	-	-	*18 570	15 340	*13 650	10 000	11 270	7 170	8 450	5 410	*7 930	5 090	9 336
	Shoe: 600 mm	1.5 m kg	-	-	-	-	*21 640	14 410	*15 430	9 500	10 960	6 900	8 300	5 270	7 820	4 970	9 355
	0 m kg	-	-	-	-	*22 810	14 010	15 200	9 180	10 740	6 700	8 200	5 180	8 030	5 080	9 127	
	CWT: 6500 kg	-1.5 m kg	-	-	*15 470	*15 470	*22 570	13 940	15 050	9 050	10 650	6 620	-	-	8 690	5 470	8 633
	-3.0 m kg	*18 020	*18 020	*24 440	*24 440	*21 150	14 070	15 100	9 100	10 720	6 680	-	-	10 100	6 330	7 822	
	-4.5 m kg	-	-	*24 570	*24 570	*18 150	14 410	*13 600	9 350	-	-	-	-	*11 920	8 260	6 575	

LIFTING CAPACITY EC380DL

			1.5 m		3.0 m		4.5 m		6.0 m		7.5 m		9.0 m		Max. reach		mm	
			Along UC	Across UC	Along UC	Across UC	Along UC	Across UC	Along UC	Across UC	Along UC	Across UC	Along UC	Across UC	Along UC	Across UC		
Boom: 6.45 m	9.0 m	kg	-	-	-	-	-	-	-	-	-	-	-	-	*6 700	*6 700	7 256	
	7.5 m	kg	-	-	-	-	-	-	-	-	*8 250	8 060	-	-	*6 260	*6 260	8 443	
	6.0 m	kg	-	-	-	-	-	-	-	-	*8 610	7 920	*7 460	5 790	*6 110	5 510	9 237	
	4.5 m	kg	-	-	-	-	-	-	*10 470	*10 470	*9 470	7 650	8 750	5 680	*6 160	4 940	9 736	
	Arm: 3.9 m	3.0 m	kg	-	-	-	-	*16 500	15 830	*12 550	10 220	*10 610	7 300	8 560	5 500	*6 390	4 630	9 984
		1.5 m	kg	-	-	-	-	*20 140	14 600	*14 540	9 610	11 050	6 970	8 360	5 320	*6 800	4 520	10 002
	Shoe: 600mm	0 m	kg	-	-	*9 650	*9 650	*22 140	13 940	15 210	9 180	10 760	6 700	8 200	5 170	7 260	4 590	9 789
		-1.5 m	kg	*9 850	*9 850	*14 680	*14 680	*22 620	13 700	14 950	8 950	10 590	6 560	8 130	5 110	7 730	4 870	9 331
	CWT: 6500kg	-3.0 m	kg	*15 310	*15 310	*21 180	*21 180	*21 860	13 740	14 910	8 920	1 050	6 540	-	-	8 740	5 480	8 587
		-4.5 m	kg	*21 850	*21 850	*27 640	*27 640	*19 720	14 010	*14 890	9 090	-	-	-	-	10 850	6 760	7 471
	-6.0 m	kg	-	-	*20 930	*20 930	*15 250	14 580	-	-	-	-	-	-	*11 390	10 110	5 767	
Boom: 6.2 m	7.5 m	kg	-	-	-	-	-	-	*10 730	*10 730	-	-	-	-	*10 940	9 450	6 717	
	6.0 m	kg	-	-	-	-	-	-	*11 270	*11 270	*10 800	7 820	-	-	*10 620	7 480	7 694	
	4.5 m	kg	-	-	-	-	*15 950	*15 950	*12 740	10 840	*11 260	7 670	-	-	10 060	6 520	8 288	
	Arm: 2.6 m	3.0 m	kg	-	-	-	-	*19 950	15 770	*14 580	10 320	11 600	7 430	-	-	9 380	6 050	8 579
		1.5 m	kg	-	-	-	-	*22 520	15 010	16 080	9 900	11 350	7 210	-	-	9 220	5 910	8 600
	Shoe: 600mm	0 m	kg	-	-	-	-	*23 070	14 750	15 800	9 650	11 190	7 060	-	-	9 560	6 100	8 351
		-1.5 m	kg	-	-	*17 930	*17 930	*22 250	14 760	15 720	9 590	11 170	7 050	-	-	10 550	6 690	7 807
	CWT: 7000kg	-3.0 m	kg	-	-	*26 840	*26 840	*20 070	14 970	*15 200	9 720	-	-	-	-	*12 570	8 050	6 898
		-4.5 m	kg	-	-	-	-	*15 500	15 450	-	-	-	-	-	-	*12 300	11 660	5 439
	Boom: 6.45 m	7.5 m	kg	-	-	-	-	-	-	-	-	-	-	-	-	*10 440	8 760	7 031
6.0 m		kg	-	-	-	-	-	-	*11 010	*11 010	*10 360	7 820	-	-	*10 380	7 040	7 969	
4.5 m		kg	-	-	-	-	*16 120	*16 120	*12 600	10 740	*10 980	7 620	-	-	9 540	6 170	8 543	
Arm: 2.6 m		3.0 m	kg	-	-	-	-	-	*14 480	10 200	11 520	7 360	-	-	8 930	5 740	8 826	
		1.5 m	kg	-	-	-	-	-	15 930	9 760	11 260	7 130	-	-	8 780	5 620	8 846	
Shoe: 600mm		0 m	kg	-	-	-	-	*22 070	14 570	15 650	9 530	11 090	6 980	-	-	9 070	5 780	8 605
		-1.5 m	kg	-	-	*14 980	*14 980	*22 050	14 600	15 590	9 470	11 060	6 950	-	-	9 950	6 300	8 079
CWT: 7000kg		-3.0 m	kg	-	-	*26 560	*26 560	*20 090	14 810	*15 360	9 590	-	-	-	-	11 900	7 480	7 204
		-4.5 m	kg	-	-	*21 140	*21 140	*16 190	15 250	-	-	-	-	-	-	*12 080	10 410	5 824
Boom: 6.45 m		7.5 m	kg	-	-	-	-	-	-	-	-	*8 870	8 050	-	-	*7 750	7 740	7 663
	6.0 m	kg	-	-	-	-	-	-	-	-	*9 530	7 980	-	-	*7 540	6 400	8 531	
	4.5 m	kg	-	-	-	-	*14 390	*14 390	*11 650	10 960	*10 300	7 750	*8 320	5 760	*7 610	5 680	9 069	
	Arm: 3.2 m	3.0 m	kg	-	-	-	-	*18 570	15 910	*13 650	10 380	*11 340	7 460	8 730	5 630	*7 930	5 310	9 336
		1.5 m	kg	-	-	-	-	*21 640	14 970	*15 430	9 880	11 330	7 180	8 580	5 500	8 090	5 190	9 355
	Shoe: 600mm	0 m	kg	-	-	-	-	*22 810	14 580	15 700	9 560	11 110	6 990	8 480	5 410	8 310	5 300	9 127
		-1.5 m	kg	-	-	*15 470	*15 470	*22 570	14 510	15 550	9 430	11 010	6 900	-	-	8 990	5 710	8 633
	CWT: 7000kg	-3.0 m	kg	*18 020	*18 020	*24 440	*24 440	*21 150	14 640	15 610	9 480	11 080	6 960	-	-	10 440	6 600	7 822
		-4.5 m	kg	-	-	*24 570	*24 570	*18 150	14 980	*13 600	9 730	-	-	-	-	*11 920	8 600	6 575
	Boom: 6.45 m	9.0 m	kg	-	-	-	-	-	-	-	-	-	-	-	-	*6 700	*6 700	7 256
7.5 m		kg	-	-	-	-	-	-	-	-	*8 250	*8 250	-	-	*6 260	*6 260	8 443	
6.0 m		kg	-	-	-	-	-	-	-	-	*8 610	8 210	*7 460	6 010	*6 110	5 730	9 237	
4.5 m		kg	-	-	-	-	-	-	*10 470	*10 470	*9 470	7 930	*8 950	5 900	*6 160	5 150	9 736	
Arm: 3.9 m		3.0 m	kg	-	-	-	-	*16 500	16 400	*12 550	10 600	*10 610	7 590	8 840	5 730	*6 390	4 840	9 984
		1.5 m	kg	-	-	-	-	*20 140	15 170	*14 540	9 990	11 420	7 250	8 650	5 550	*6 800	4 720	10 002
Shoe: 600mm		0 m	kg	-	-	*9 650	*9 650	*22 140	14 510	15 710	9 560	11 130	6 990	8 490	5 400	*7 480	4 790	9 789
		-1.5 m	kg	*9 850	*9 850	*14 680	*14 680	*22 620	14 270	15 450	9 330	10 960	6 840	8 420	5 340	8 000	5 090	9 331
CWT: 7000kg		-3.0 m	kg	*15 310	*15 310	*21 180	*21 180	*21 860	14 310	15 420	9 300	10 940	6 830	-	-	9 040	5 730	8 587
		-4.5 m	kg	*21 850	*21 850	*27 640	*27 640	*19 720	14 580	*14 890	9 470	-	-	-	-	11 210	7 050	7 471
	-6.0 m	kg	-	-	*20 930	*20 930	*15 250	15 150	-	-	-	-	-	-	*11 390	10 510	5 767	

Specifications

LIFTING CAPACITY EC480DL, fixed undercarriage

		3.0 m		4.5 m		6.0 m		7.5 m		9.0 m		10.5 m		Max. reach			
		Along UC	Across UC	Along UC	Across UC	Along UC	Across UC	Along UC	Across UC	Along UC	Across UC	Along UC	Across UC	Along UC	Across UC	mm	
Boom: 6.5 m Arm: 2.55 m Shoe: 600 mm CWT: 9050 kg	7.5 m	kg	-	-	-	-	-	-	-	-	-	-	-	-	*12 430	10 810	7 249
	6.0 m	kg	-	-	-	-	*13 390	*13 390	*12 350	10 180	-	-	-	-	*12 280	8 880	8 143
	4.5 m	kg	-	-	*19 980	*19 980	*15 270	13 820	*13 110	9 920	-	-	-	-	12 330	7 900	8 686
	3.0 m	kg	-	-	*24 400	19 800	*17 390	13 170	*14 160	9 600	-	-	-	-	11 630	7 420	8 944
	1.5 m	kg	-	-	*17 490	*17 490	*19 000	12 680	14 930	9 330	-	-	-	-	11 510	7 310	8 942
	0 m	kg	-	-	*25 680	18 950	*19 670	12 440	14 750	9 160	-	-	-	-	11 940	7 550	8 680
	-1.5 m	kg	*18 840	*18 840	*25 280	19 030	*19 250	12 400	14 730	9 150	-	-	-	-	13 140	8 260	8 132
	-3.0 m	kg	*29 180	*29 180	*22 630	19 300	*17 440	12 560	-	-	-	-	-	-	*13 600	9 810	7 231
	-4.5 m	kg	-	-	*17 530	*17 530	-	-	-	-	-	-	-	-	*12 950	*12 950	5 813
Boom: 6.5 m Arm: 3.0 m Shoe: 600 mm CWT: 9050 kg	7.5 m	kg	-	-	-	-	-	-	*11 300	10 270	-	-	-	-	*10 910	9 820	7 692
	6.0 m	kg	-	-	-	-	-	-	*11 480	10 160	-	-	-	-	*10 590	8 180	8 539
	4.5 m	kg	-	-	*18 230	*18 230	*14 280	13 830	*12 360	9 860	*11 470	7 390	-	-	*10 670	7 310	9 058
	3.0 m	kg	-	-	*22 890	19 900	*16 480	13 110	*13 500	9 500	11 420	7 240	-	-	10 840	6 870	9 305
	1.5 m	kg	-	-	*25 180	18 920	*18 300	12 540	*14 530	9 180	11 250	7 080	-	-	10 710	6 750	9 303
	0 m	kg	-	-	*26 410	18 600	*19 260	12 210	14 550	8 960	11 150	6 990	-	-	11 060	6 940	9 052
	-1.5 m	kg	*19 530	*19 530	*25 590	18 600	*19 190	12 110	14 480	8 900	-	-	-	-	12 050	7 520	8 528
	-3.0 m	kg	*31 560	*31 560	*23 430	18 830	*17 880	12 220	*13 630	9 030	-	-	-	-	*13 100	8 780	7 675
	-4.5 m	kg	-	-	*19 220	*19 220	*14 290	12 620	-	-	-	-	-	-	*13 000	11 680	6 359
Boom: 7.0 m Arm: 2.55 m Shoe: 600 mm CWT: 9050 kg	9.0 m	kg	-	-	-	-	-	-	-	-	-	-	-	-	*11 860	*11 860	6 619
	7.5 m	kg	-	-	-	-	-	-	*11 320	10 280	-	-	-	-	*11 440	9 430	7 886
	6.0 m	kg	-	-	-	-	*13 060	*13 060	*11 700	10 110	-	-	-	-	*11 360	7 940	8 714
	4.5 m	kg	-	-	-	-	*15 150	13 550	*12 670	9 790	*11 500	7 430	-	-	11 150	7 140	9 223
	3.0 m	kg	-	-	-	-	*17 330	12 860	*13 820	9 440	11 430	7 270	-	-	10 580	6 740	9 466
	1.5 m	kg	-	-	-	-	*18 870	12 390	14 740	9 150	11 270	7 120	-	-	10 480	6 640	9 464
	0 m	kg	-	-	-	-	*19 450	12 180	14 540	8 980	11 180	7 050	-	-	10 820	6 840	9 217
	-1.5 m	kg	-	-	*24 720	18 780	*19 090	12 170	14 510	8 950	-	-	-	-	11 760	7 400	8 703
	-3.0 m	kg	*27 580	*27 580	*22 570	19 020	*17 700	12 310	*13 770	9 100	-	-	-	-	*12 720	8 580	7 870
-4.5 m	kg	-	-	*18 710	*18 710	*14 430	12 700	-	-	-	-	-	-	*12 460	11 220	6 594	
Boom: 7.0 m Arm: 3.0 m Shoe: 600 mm CWT: 9050 kg	9.0 m	kg	-	-	-	-	-	-	-	-	-	-	-	-	*10 770	*10 770	7 134
	7.5 m	kg	-	-	-	-	-	-	*10 380	10 300	-	-	-	-	*10 510	8 610	8 322
	6.0 m	kg	-	-	-	-	-	-	*10 910	10 080	*10 490	7 480	-	-	*10 500	7 320	9 109
	4.5 m	kg	-	-	*18 910	*18 910	*14 150	13 550	*11 950	9 720	*10 830	7 340	-	-	10 390	6 610	9 597
	3.0 m	kg	-	-	-	-	*16 420	12 790	*13 170	9 330	11 320	7 140	-	-	9 870	6 240	9 831
	1.5 m	kg	-	-	-	-	*18 170	12 230	*14 240	8 990	11 110	6 960	-	-	9 760	6 130	9 829
	0 m	kg	-	-	*18 120	*18 120	*19 030	11 930	14 340	8 770	10 980	6 840	-	-	10 040	6 280	9 591
	-1.5 m	kg	*13 850	*13 850	*25 110	18 290	*18 980	11 860	14 250	8 700	10 980	6 840	-	-	10 820	6 750	9 099
	-3.0 m	kg	*25 800	*25 800	*23 270	18 520	*17 960	11 970	*14 100	8 790	-	-	-	-	*12 180	7 720	8 306
-4.5 m	kg	*25 880	*25 880	*19 960	18 960	*15 450	12 280	-	-	-	-	-	-	*12 260	9 780	7 111	
-6.0 m	kg	-	-	-	-	-	-	*10 300	*10 300	-	-	-	-	*10 360	10 330	7 583	
Boom: 7.0 m Arm: 3.35 m Shoe: 600 mm CWT: 9050 kg	9.0 m	kg	-	-	-	-	-	-	*10 010	*10 010	-	-	-	-	*9 800	8 200	8 709
	7.5 m	kg	-	-	-	-	-	-	*10 630	10 330	*10 190	7 720	-	-	*9 600	7 080	9 463
	6.0 m	kg	-	-	*17 950	*17 950	*13 760	*13 760	*11 740	9 980	*10 670	7 560	-	-	*9 680	6 450	9 933
	4.5 m	kg	-	-	*22 870	19 800	*16 130	13 150	*13 040	9 580	*11 350	7 350	-	-	9 570	6 110	10 159
	3.0 m	kg	-	-	*15 840	*15 840	*18 080	12 560	*14 210	9 230	11 310	7 160	-	-	9 460	6 010	10 158
	1.5 m	kg	-	-	*19 420	18 570	*19 170	12 220	14 570	9 000	11 160	7 020	-	-	9 710	6 140	9 928
	0 m	kg	*14 040	*14 040	*25 880	18 570	*19 340	12 100	14 450	8 890	11 110	6 970	-	-	10 390	6 550	9 454
	-1.5 m	kg	*23 900	*23 900	*24 290	18 740	*18 570	12 150	14 490	8 930	-	-	-	-	11 760	7 390	8 694
	-3.0 m	kg	*28 410	*28 410	*21 330	19 100	*16 470	12 390	*12 380	9 180	-	-	-	-	*12 190	9 090	7 562
-4.5 m	kg	-	-	-	-	-	-	-	-	-	-	-	-	*8 370	*8 370	8 244	

LIFTING CAPACITY EC480DL, fixed undercarriage

			3.0 m		4.5 m		6.0 m		7.5 m		9.0 m		10.5 m		Max. reach		
			Along UC	Across UC	Along UC	Across UC	Along UC	Across UC	Along UC	Across UC	Along UC	Across UC	Along UC	Across UC	Along UC	Across UC	mm
Boom: 7.0 m Arm: 3.9 m Shoe: 600mm CWT: 9050kg	9.0 m	kg	-	-	-	-	-	-	-	-	*9250	7 850	-	-	*7930	7 410	9 288
	7.5 m	kg	-	-	-	-	-	-	*9780	*9780	*9410	7 760	-	-	*7770	6 470	9 999
	6.0 m	kg	-	-	-	-	*12 610	*12 610	*10 930	10 020	*9990	7 560	-	-	*7840	5 910	10 444
	4.5 m	kg	-	-	*20 840	20 140	*15 060	13 240	*12 300	9 580	*10 760	7 320	9 060	5 760	*8090	5 620	10 659
	3.0 m	kg	-	-	*21 560	18 890	*17 210	12 540	*13 600	9 180	11 250	7 080	8 930	5 640	*8570	5 520	10 657
	1.5 m	kg	-	-	*21 410	18 360	*18 610	12 100	14 470	8 890	11 050	6 910	-	-	8 930	5 610	10 439
	0 m	kg	*14 060	*14 060	*25 990	18 230	*19 130	11 900	14 290	8 730	10 950	6 810	-	-	9 470	5 940	9 989
	-1.5 m	kg	*21 670	*21 670	*24 880	18 330	*18 740	11 890	14 270	8 710	10 990	6 850	-	-	10 560	6 600	9 275
	-3.0 m	kg	*31 060	*31 060	*22 520	18 640	*17 220	12 070	*13 380	8 870	-	-	-	-	*11 590	7 900	8 224
	-4.5 m	kg	-	-	*18 130	*18 130	*13 640	12 510	-	-	-	-	-	-	*11 580	10 840	6 678
Boom: 7.0 m Arm: 4.8 m Shoe: 600mm CWT: 9050kg	9.0 m	kg	-	-	-	-	-	-	-	-	*8 030	8 000	-	-	*7 580	*7 580	9 163
	7.5 m	kg	-	-	-	-	-	-	-	-	*7 860	*7 860	-	-	*7 290	6 470	10 111
	6.0 m	kg	-	-	-	-	-	-	-	-	*8 220	7 860	*8 250	6 000	*7 220	5 720	10 766
	4.5 m	kg	-	-	-	-	-	-	*9 570	*9 570	*8 910	7 610	*8 550	5 880	*7 320	5 250	11 181
	3.0 m	kg	-	-	*17 570	*17 570	*13 220	13 220	*11 040	9 670	*9 780	7 320	*9 020	5 720	*7 570	4 990	11 382
	1.5 m	kg	-	-	*21 990	19 240	15 670	12 650	*12 510	9 180	*10 680	7 030	8 860	5 550	7 820	4 880	11 380
	0 m	kg	-	-	*24 650	18 270	17 530	12 030	*13 720	8 790	10 940	6 780	8 710	5 410	7 940	4 930	11 176
	-1.5 m	kg	*14 230	*14 230	*25 660	17 870	18 570	11 680	14 110	8 540	10 760	6 620	8 620	5 340	7 840	5 160	10 758
	-3.0 m	kg	*19 870	*19 870	*25 380	17 810	18 750	11 560	13 990	8 440	10 700	6 570	-	-	9 120	5 640	10 098
	-4.5 m	kg	*27 230	*27 230	*23 910	18 000	17 970	11 630	14 050	8 490	10 810	6 660	-	-	10 580	6 530	9 145
-6.0 m	kg	*29 270	*29 270	*20 870	18 440	15 820	11 910	*12 010	8 750	-	-	-	-	*11 290	8 340	7 787	

LIFTING CAPACITY EC480DL, retractable undercarriage

			3.0 m		4.5 m		6.0 m		7.5 m		9.0 m		10.5 m		Max. reach		
			Along UC	Across UC	Along UC	Across UC	Along UC	Across UC	Along UC	Across UC	Along UC	Across UC	Along UC	Across UC	Along UC	Across UC	mm
Boom: 6.5 m Arm: 2.55 m Shoe: 600mm CWT: 9750kg	7.5 m	kg	-	-	-	-	-	-	-	-	-	-	-	-	*12 430	11 970	7 249
	6.0 m	kg	-	-	-	-	*13 390	*13 390	*12 350	11 280	-	-	-	-	*12 280	9 870	8 143
	4.5 m	kg	-	-	*19 980	*19 980	*15 270	*15 270	*13 110	11 020	-	-	-	-	*12 350	8 800	8 686
	3.0 m	kg	-	-	*24 400	22 270	*17 390	14 700	*14 160	10 700	-	-	-	-	12 230	8 280	8 944
	1.5 m	kg	-	-	*17 490	*17 490	*19 000	14 210	*15 060	10 420	-	-	-	-	12 110	8 170	8 942
	0 m	kg	-	-	*25 680	21 410	*19 670	13 950	*15 490	10 260	-	-	-	-	12 570	8 440	8 680
	-1.5 m	kg	*18 840	*18 840	*25 280	21 490	*19 250	13 910	*15 070	10 240	-	-	-	-	*13 470	9 230	8 132
	-3.0 m	kg	*29 180	*29 180	*22 630	21 770	*17 440	14 080	-	-	-	-	-	-	*13 600	10 960	7 231
	-4.5 m	kg	-	-	*17 530	*17 530	-	-	-	-	-	-	-	-	*12 950	*12 950	5 813
	-7.5 m	kg	-	-	-	-	-	-	*11 300	*11 300	-	-	-	-	*10 910	10 890	7 692
Boom: 7.0 m Arm: 4.8 m Shoe: 600mm CWT: 9050kg	6.0 m	kg	-	-	-	-	-	-	*11 480	11 270	-	-	-	-	*10 590	9 110	8 539
	4.5 m	kg	-	-	*18 230	*18 230	*14 280	*14 280	*12 360	10 970	*11 470	8 250	-	-	*10 680	8 160	9 058
	3.0 m	kg	-	-	*22 890	22 390	*16 480	14 650	*13 500	10 600	*11 900	8 090	-	-	*11 100	7 690	9 305
	1.5 m	kg	-	-	*25 180	21 380	*18 300	14 060	*14 530	10 270	11 850	7 940	-	-	11 280	7 570	9 303
	0 m	kg	-	-	*26 410	21 050	*19 260	13 730	*15 150	10 060	11 750	7 850	-	-	11 650	7 790	9 052
	-1.5 m	kg	*19 530	*19 530	*25 590	21 060	*19 190	13 630	*15 050	9 990	-	-	-	-	12 690	8 440	8 528
	-3.0 m	kg	*31 560	*31 560	*23 430	21 290	*17 880	13 740	*13 630	10 130	-	-	-	-	*13 100	9 840	7 675
	-4.5 m	kg	-	-	*19 220	*19 220	*14 300	14 140	-	-	-	-	-	-	*13 000	*13 000	6 359

Specifications

LIFTING CAPACITY EC480DL, retractable undercarriage

		3.0 m		4.5 m		6.0 m		7.5 m		9.0 m		10.5 m		Max. reach			
		Along UC	Across UC	Along UC	Across UC	Along UC	Across UC	Along UC	Across UC	Along UC	Across UC	Along UC	Across UC	Along UC	Across UC	mm	
Boom: 7.0 m Arm: 2.55 m Shoe: 600 mm CWT: 9750 kg	9.0 m	kg	-	-	-	-	-	-	-	-	-	-	-	*11 860	*11 860	6 619	
	7.5 m	kg	-	-	-	-	-	*11 320	*11 320	-	-	-	-	*11 440	10 460	7 886	
	6.0 m	kg	-	-	-	-	*13 060	*13 060	*11 700	11 220	-	-	-	*11 360	8 830	8 714	
	4.5 m	kg	-	-	-	-	*15 150	15 080	*12 670	10 890	*11 500	8 290	-	-	*11 450	7 970	9 223
	3.0 m	kg	-	-	-	-	*17 330	14 390	*13 820	10 540	*11 980	8 130	-	-	11 140	7 540	9 466
	1.5 m	kg	-	-	-	-	*18 870	13 910	*14 770	10 240	11 870	7 980	-	-	11 040	7 440	9 464
	0 m	kg	-	-	-	-	*19 450	13 700	*15 270	10 070	11 780	7 900	-	-	11 400	7 660	9 217
	-1.5 m	kg	-	-	*24 720	21 230	*19 090	13 680	*15 100	10 040	-	-	-	-	12 390	8 290	8 703
	-3.0 m	kg	*27 580	*27 580	*22 570	21 480	*17 710	13 830	*13 780	10 190	-	-	-	-	*12 720	9 600	7 870
-4.5 m	kg	-	-	*18 710	*18 710	*14 440	14 220	-	-	-	-	-	-	*12 460	*12 460	6 594	
Boom: 7.0 m Arm: 3.00 m Shoe: 600 mm CWT: 9750 kg	9.0 m	kg	-	-	-	-	-	-	-	-	-	-	-	*10 770	*10 770	7 134	
	7.5 m	kg	-	-	-	-	-	*10 380	*10 380	-	-	-	-	*10 510	9 570	8 322	
	6.0 m	kg	-	-	-	-	-	*10 910	*10 910	*10 490	8 340	-	-	*10 500	8 170	9 109	
	4.5 m	kg	-	-	*18 910	*18 910	*14 150	*14 150	*11 950	10 830	*10 830	8 200	-	-	*10 630	7 390	9 597
	3.0 m	kg	-	-	-	-	*16 420	14 320	*13 170	10 420	*11 420	8 000	-	-	10 400	7 000	9 831
	1.5 m	kg	-	-	-	-	*18 170	13 740	*14 240	10 080	11 710	7 810	-	-	10 290	6 890	9 829
	0 m	kg	-	-	*18 120	*18 120	*19 030	13 440	*14 900	9 860	11 580	7 690	-	-	10 590	7 070	9 591
	-1.5 m	kg	*13 850	*13 850	*25 110	20 740	*18 980	13 370	*14 950	9 790	11 580	7 690	-	-	11 410	7 590	9 099
	-3.0 m	kg	*25 800	*25 800	*23 270	20 970	*17 960	13 480	*14 100	9 880	-	-	-	-	*12 180	8 670	8 306
-4.5 m	kg	*25 880	*25 880	*19 960	*19 960	*15 450	13 800	-	-	-	-	-	-	*12 260	10 960	7 111	
Boom: 7.0 m Arm: 3.35 m Shoe: 600 mm CWT: 9750 kg	9.0 m	kg	-	-	-	-	-	*10 300	*10 300	-	-	-	-	*10 360	*10 360	7 583	
	7.5 m	kg	-	-	-	-	-	*10 010	*10 010	-	-	-	-	*9 800	9 100	8 709	
	6.0 m	kg	-	-	-	-	-	*10 630	*10 630	*10 190	8 580	-	-	*9 600	7 880	9 463	
	4.5 m	kg	-	-	*17 950	*17 950	*13 760	*13 760	*11 740	11 080	*10 670	8 420	-	-	*9 680	7 200	9 933
	3.0 m	kg	-	-	*22 870	22 280	*16 130	14 680	*13 040	10 680	*11 350	8 210	-	-	*10 010	6 840	10 159
	1.5 m	kg	-	-	*15 840	*15 840	*18 080	14 080	*14 210	10 330	11 910	8 010	-	-	9 970	6 740	10 158
	0 m	kg	-	-	*19 420	*19 420	*19 170	13 730	*15 010	10 090	11 750	7 870	-	-	10 230	6 890	9 928
	-1.5 m	kg	*14 040	*14 040	*25 880	21 010	*19 340	13 610	15 210	9 980	11 700	7 820	-	-	10 950	7 350	9 454
	-3.0 m	kg	*23 910	*23 910	*24 290	21 190	*18 570	13 670	*14 630	10 020	-	-	-	-	*11 980	8 280	8 694
-4.5 m	kg	*28 410	*28 410	*21 330	*21 330	*16 470	13 910	*12 380	10 280	-	-	-	-	*12 190	10 170	7 562	
Boom: 7.0 m Arm: 3.9 m Shoe: 600 mm CWT: 9750 kg	9.0 m	kg	-	-	-	-	-	-	-	-	-	-	-	*8 370	*8 370	8 244	
	7.5 m	kg	-	-	-	-	-	-	-	-	*9 250	8 710	-	-	*7 930	*7 930	9 288
	6.0 m	kg	-	-	-	-	-	-	*9 780	*9 780	*9 410	8 620	-	-	*7 770	7 210	9 999
	4.5 m	kg	-	-	-	-	*12 610	*12 610	*10 930	*10 930	*9 990	8 420	-	-	*7 840	6 620	10 444
	3.0 m	kg	-	-	*20 840	*20 840	*15 060	14 770	*12 300	10 690	*10 760	8 170	9 550	6 460	*8 090	6 300	10 659
	1.5 m	kg	-	-	*21 560	21 350	*17 210	14 070	*13 600	10 280	*11 530	7 940	9 420	6 340	*8 570	6 200	10 657
	0 m	kg	-	-	*21 410	20 800	*18 610	13 610	*13 600	9 980	11 650	7 760	-	-	*9 320	6 320	10 439
	-1.5 m	kg	*14 060	*14 060	*25 990	20 670	*19 130	13 410	*15 010	9 820	11 550	7 670	-	-	9 990	6 680	9 989
	-3.0 m	kg	*21 670	*21 670	*24 880	20 780	*18 740	13 400	*14 760	9 800	11 590	7 700	-	-	11 130	7 420	9 275
-4.5 m	kg	*31 060	*31 060	*22 520	21 090	*17 220	13 580	*13 380	9 960	-	-	-	-	*11 590	8 860	8 224	
-6.0 m	kg	-	-	*18 130	*18 130	*13 640	*13 640	-	-	-	-	-	-	*11 580	*11 580	6 678	
Boom: 7.0 m Arm: 4.8 m Shoe: 600 mm CWT: 9750 kg	9.0 m	kg	-	-	-	-	-	-	-	*8 030	*8 030	-	-	*7 580	*7 580	9 163	
	7.5 m	kg	-	-	-	-	-	-	-	*7 860	*7 860	-	-	*7 290	7 210	10 111	
	6.0 m	kg	-	-	-	-	-	-	-	*8 220	*8 220	*8 250	6 700	*7 220	6 400	10 766	
	4.5 m	kg	-	-	-	-	-	-	*9 570	*9 570	*8 910	8 470	*8 550	6 580	*7 320	5 900	11 181
	3.0 m	kg	-	-	*17 570	*17 570	*13 220	*13 220	*11 040	10 780	*9 780	8 180	*9 030	6 420	*7 580	5 620	11 382
	1.5 m	kg	-	-	*21 990	21 710	*15 670	14 180	*12 510	10 280	*10 680	7 880	9 350	6 250	*8 020	5 520	11 380
	0 m	kg	-	-	*24 650	20 720	*17 530	13 550	*13 720	9 890	*11 460	7 640	9 200	6 110	8 400	5 580	11 176
	-1.5 m	kg	*14 240	*14 240	*25 660	20 310	*18 570	13 190	*14 500	9 630	11 360	7 470	9 110	6 040	8 810	5 840	10 758
	-3.0 m	kg	*19 870	*19 870	*25 380	20 250	*18 750	13 070	*14 700	9 530	11 300	7 420	-	-	9 640	6 370	10 098
-4.5 m	kg	*27 230	*27 230	*23 910	20 450	*17 970	13 140	*14 090	9 580	*11 110	7 520	-	-	*10 820	7 370	9 145	
-6.0 m	kg	*29 270	*29 270	*20 870	*20 870	*15 820	13 430	*12 010	9 850	-	-	-	-	*11 290	9 380	7 787	

LIFTING CAPACITY EC380DLR

		4.5 m		6.0 m		7.5 m		9.0 m		10.5 m		12.0 m		Max. reach		mm	
		Along UC	Across UC	Along UC	Across UC	Along UC	Across UC	Along UC	Across UC	Along UC	Across UC	Along UC	Across UC	Along UC	Across UC		
Boom: 8.5 m Arm: 5.0 m Shoe: 800mm CWT: 8500kg	10.5 m	kg	-	-	-	-	-	-	-	-	-	-	-	-	*5 170	*5 170	10 111
	9.0 m	kg	-	-	-	-	-	-	-	-	*5 440	*5 440	-	-	*4 920	4 830	11 195
	7.5 m	kg	-	-	-	-	-	-	-	-	*5 520	5 440	-	-	*4 790	4 210	11 995
	6.0 m	kg	-	-	-	-	-	-	*6 050	*6 050	*5 830	5 310	*5 770	4 170	*4 770	3 810	12 564
	4.5 m	kg	-	-	-	-	*7 610	*7 610	*6 780	6 550	*6 280	5 120	*6 010	4 080	*4 830	3 540	12 934
	3.0 m	kg	-	-	*11 240	11 120	*8 910	8 120	*7 610	6 230	*6 820	4 920	6 160	3 960	*4 970	3 380	13 122
	1.5 m	kg	-	-	*13 190	10 330	*10 150	7 640	*8 430	5 920	*7 370	4 730	6 040	3 840	*5 200	3 310	13 135
	0 m	kg	-	-	*14 550	9 830	*11 150	7 280	9 000	5 680	7 200	4 560	5 930	3 740	5 290	3 320	12 974
	-1.5 m	kg	*9 860	*9 860	*15 280	9 580	11 460	7 050	8 810	5 510	7 080	4 450	5 860	3 680	5 460	3 420	12 633
	-3.0 m	kg	*13 220	*13 220	*15 500	9 500	11 350	6 950	8 720	5 420	7 020	4 390	5 860	3 680	5 800	3 640	12 096
	-4.5 m	kg	*17 640	14 850	*15 250	9 560	11 360	6 960	8 720	5 420	7 050	4 420	-	-	6 380	4 020	11 335
	-6.0 m	kg	*18 830	15 160	*14 470	9 730	11 490	7 070	8 830	5 520	-	-	-	-	7 380	4 670	10 300
-7.5 m	kg	*16 650	15 630	*12 950	10 040	*10 300	7 320	-	-	-	-	-	-	*8 130	5 880	8 893	
-9.0 m	kg	*12 990	*12 990	*9 990	*9 990	-	-	-	-	-	-	-	-	*8 310	*8 310	6 889	

LIFTING CAPACITY EC480DLR, fixed undercarriage

		4.5 m		6.0 m		7.5 m		9.0 m		10.5 m		12.0 m		Max. reach		mm	
		Along UC	Across UC	Along UC	Across UC	Along UC	Across UC	Along UC	Across UC	Along UC	Across UC	Along UC	Across UC	Along UC	Across UC		
Boom: 8.5 m Arm: 5.0 m Shoe: 800mm CWT: 8500kg	12.0 m	kg	-	-	-	-	-	-	-	-	-	-	-	-	*5 190	*5 190	11 167
	10.5 m	kg	-	-	-	-	-	-	-	-	*5 340	*5 340	-	-	*4 830	*4 830	12 330
	9.0 m	kg	-	-	-	-	-	-	-	-	*5 180	*5 180	-	-	*4 610	4 420	13 221
	7.5 m	kg	-	-	-	-	-	-	-	-	*5 290	*5 290	*5 440	4 240	*4 490	3 960	13 892
	6.0 m	kg	-	-	-	-	-	-	-	-	*5 560	5 260	*5 520	4 190	*4 440	3 640	14 374
	4.5 m	kg	-	-	-	-	-	-	*6 300	*6 300	*5 940	5 080	*5 740	4 090	*4 450	3 430	14 686
	3.0 m	kg	*11 680	*11 680	*9 230	*9 230	*7 830	7 670	*6 950	6 050	*6 380	4 870	*6 020	3 960	*4 520	3 290	14 839
	1.5 m	kg	*13 930	12 590	*10 660	9 310	*8 790	7 210	*7 610	5 750	*6 840	4 670	6 300	3 830	*4 660	3 230	14 837
	0 m	kg	*15 600	11 810	*11 860	8 760	*9 640	6 830	*8 220	5 490	*7 270	4 490	6 180	3 720	*4 870	3 240	14 682
	-1.5 m	kg	*16 620	11 370	*12 720	8 390	*10 310	6 560	*8 730	5 290	7 240	4 350	6 100	3 650	*5 170	3 330	14 367
	-3.0 m	kg	*17 090	11 190	*13 240	8 200	10 750	6 390	8 630	5 160	7 150	4 270	6 080	3 620	*5 580	3 500	13 883
	-4.5 m	kg	*17 080	11 180	*13 400	8 140	10 680	6 320	8 590	5 120	7 140	4 270	-	-	*6 190	3 790	13 209
-6.0 m	kg	*16 590	11 320	*13 160	8 210	10 730	6 370	8 640	5 170	7 260	4 370	-	-	7 050	4 260	12 314	
-7.5 m	kg	*15 510	11 600	*12 400	8 400	*10 120	6 540	*8 210	5 360	-	-	-	-	*7 300	5 030	11 145	
-9.0 m	kg	*13 580	12 060	*10 810	8 770	*8 470	6 900	-	-	-	-	-	-	*7 390	6 420	9 601	

LIFTING CAPACITY EC480DLR, retractable undercarriage

		4.5 m		6.0 m		7.5 m		9.0 m		10.5 m		12.0 m		Max. reach		mm	
		Along UC	Across UC	Along UC	Across UC	Along UC	Across UC	Along UC	Across UC	Along UC	Across UC	Along UC	Across UC	Along UC	Across UC		
Boom: 8.5 m Arm: 5.0 m Shoe: 800mm CWT: 8500kg	12.0 m	kg	-	-	-	-	-	-	-	-	-	-	-	-	*5 190	*5 190	11 167
	10.5 m	kg	-	-	-	-	-	-	-	-	*5 340	*5 340	-	-	*4 830	*4 830	12 330
	9.0 m	kg	-	-	-	-	-	-	-	-	*5 180	*5 180	-	-	*4 610	*4 610	13 221
	7.5 m	kg	-	-	-	-	-	-	-	-	*5 290	*5 290	*5 440	4 560	*4 490	4 260	13 892
	6.0 m	kg	-	-	-	-	-	-	-	-	*5 560	*5 560	*5 520	4 510	*4 440	3 930	14 374
	4.5 m	kg	-	-	-	-	-	-	*6 300	*6 300	*5 940	5 440	*5 740	4 400	*4 450	3 710	14 686
	3.0 m	kg	*11 680	*11 680	*9 230	*9 230	*7 830	*7 830	*6 950	6 490	*6 380	5 240	*6 020	4 270	*4 520	3 570	14 839
	1.5 m	kg	*13 930	13 580	*10 660	10 010	*8 790	7 750	*7 610	6 180	*6 840	5 030	*6 320	4 150	*4 660	3 510	14 837
	0 m	kg	*15 600	12 780	*11 860	9 450	*9 640	7 360	*8 220	5 920	*7 270	4 850	6 290	4 040	*4 870	3 520	14 682
	-1.5 m	kg	*16 620	12 340	*12 720	9 080	*10 310	7 080	*8 730	5 720	7 360	4 720	6 210	3 960	*5 170	3 610	14 367
	-3.0 m	kg	*17 090	12 150	*13 240	8 880	*10 760	6 910	8 770	5 590	7 270	4 640	6 180	3 940	*5 580	3 800	13 883
	-4.5 m	kg	*17 080	12 150	*13 400	8 820	10 850	6 850	8 730	5 550	7 260	4 630	-	-	*6 190	4 110	13 209
-6.0 m	kg	*16 590	12 290	*13 160	8 890	*10 770	6 900	8 780	5 600	7 380	4 740	-	-	*7 090	4 610	12 314	
-7.5 m	kg	*15 510	12 570	*12 400	9 090	*10 120	7 060	*8 210	5 790	-	-	-	-	*7 300	5 430	11 145	
-9.0 m	kg	*13 580	13 040	*10 810	9 460	*8 470	7 440	-	-	-	-	-	-	*7 390	6 910	9 601	

Equipment

STANDARD EQUIPMENT

	EC380D	EC480D
Engine		
Turbocharged, 4 stroke diesel engine with water cooling, direct injection and charged air cooler	•	•
Air filter with indicator	•	•
Air intake heater	•	•
Cyclone pre-cleaner	•	•
Electric engine shut-off	•	•
Fuel filter and water separator	•	•
Alternator, 80 A	•	•
Electric/Electronic control system		
Contronics	•	•
– Advanced mode control system	•	•
– Self-diagnostic system	•	•
Machine status indication	•	•
Engine speed sensing power control	•	•
Automatic idling system	•	•
One-touch power boost	•	•
Safety stop/start function	•	•
Adjustable LCD color monitor	•	•
Master electrical disconnect switch	•	•
Engine restart prevention circuit	•	•
High-capacity halogen lights:	•	•
– Frame-mounted 2	•	•
– Boom-mounted 2	•	•
Batteries, 2 x 12 V / 200 Ah	•	•
Start motor, 24 V / 7 kW	•	•
Hydraulic system		
Automatic sensing hydraulic system	•	•
– Summation system	•	•
– Boom priority	•	•
– Arm priority	•	•
– Swing priority	•	•
“ECO” mode fuel saving technology	•	•
Boom and arm regeneration valves	•	•
Swing anti-rebound valves	•	•
Boom and arm holding valves	•	•
Multi-stage filtering system	•	•
Cylinder cushioning	•	•
Cylinder contamination seals	•	•
Auxiliary hydraulic valve	•	•
Automatic two-speed travel motors	•	•
Hydraulic oil, ISO VG 46	•	•
Frame		
Access way with handrail	•	•
Tool storage area	•	•
Punched metal anti-slip plates	•	•
Under cover	•	•
Cab and interior		
Silicon oil and rubber mounts with spring	•	•
Adjustable operator seat with heater and joystick control console	•	•
Control joysticks with 4 switches each	•	•
Heater & air-conditioner, automatic	•	•
Flexible antenna	•	•
AM/FM stereo with CD player, MP3 and USB input	•	•
Hydraulic safety lock lever	•	•

	EC380D	EC480D
Cab, all-weather sound suppressed, includes:		
– Cup holders	•	•
– Door locks	•	•
– Tinted glass	•	•
– Floor mat	•	•
– Horn	•	•
– Large storage area	•	•
– Pull-up type front window	•	•
– Removable lower windshield	•	•
– Seat belt	•	•
– Safety glass	•	•
– Sun screens, front, roof, rear	•	•
– Rain shield	•	•
– Windshield wiper with intermittent feature	•	•
Master key	•	•
Undercarriage		
Under cover (heavy duty)	•	•
Hydraulic track adjusters	•	•
Greased and sealed track link	•	•
Track Guard	•	•

OPTIONAL EQUIPMENT

	EC380D	EC480D
Engine		
Block heater: 240 V	•	•
Oil bath pre-cleaner	•	•
Diesel coolant heater, 5 kW	•	•
Water separator with heater	•	•
Extra water separator		
Auto engine shutdown	•	•
Fuel filler pump, 35 lpm, 50 lpm with automatic shut-off	•	•
Electric		
Extra lights :		
– Cab-mounted 3 (front 2, rear 1)	•	•
– Boom-mounted 2	•	•
– Counterweight-mounted 1	•	•
Travel alarm	•	•
Anti-theft system	•	•
Rotating warning beacon	•	•
Hydraulic system		
Hose rupture valve: boom, arm	•	•
Overload warning device	•	•
Boom float function with HRV	•	•
Boom float function without HRV	•	•
Hydraulic piping:		
– Work tool management system (up to 20 programmable memories)	•	•
– Hammer & shear, 1 and 2 pump flow	•	•
– Hammer & shear: variable flow and pressure pre-setting	•	•
– Additional return filter	•	•
– Slope & rotator	•	•
– Grapple	•	•
– Oil leak (drain) line	•	•
– Quick coupler piping	•	•

OPTIONAL EQUIPMENT

	EC380D	EC480D
Volvo hydraulic quick coupler S3, U46	•	•
Hydraulic oil, ISO VG 32, 68	•	•
Hydraulic oil, biodegradable 46	•	•
Hydraulic oil, longlife oil 32, 46, 68	•	•
Cab and interior		
ROPS (ISO12117-2) certified cab	•	•
Fabric seat without heater	•	•
Fabric seat with heater and air suspension	•	•
Control joysticks with semi-long	•	•
Control joysticks with 3 switch & 1 proportional	•	•
Opening top hatch	•	•
Falling object guard (FOG)	•	•
– Frame-mounted	•	•
– Cab-mounted	•	•
Cab-mounted falling object protective structure (FOPS)	•	•
Smoker kit (ashtray and lighter)	•	•
Safety net for front window	•	•
Sunlight protection, roof (steel)	•	•
Lower wiper with intermittent control	•	•
Rear view camera	•	•
Specific key	•	•
Frame		
Walk way	•	•
Rear view mirror on CWT	•	•
Cabin entrance	•	•
Full height counterweight:		
6 500 kg, 7 000 kg, 7 550 kg	•	•
8 500 kg for long reach	•	•
8 450 kg, 9 050 kg, 9 750 kg	•	•
10 300 kg for long reach	•	•
Undercarriage		
Full track guard	•	•
Mechanically retractable track gauge	•	•
Track shoes		
600/700/800/900 mm with triple grousers	•	•
Track shoes 600 mm HD with triple grousers	•	•
Track shoes 600 mm with double grousers	•	•
Digging equipment		
Boom: 6.2 m, 6.45 m monoblock / 8.5 m long reach	•	•
Arm: 2.6 m, 3.2 m, 3.9 m / 5.0 m long reach	•	•
Boom: 6.5 m, 7.0 m monoblock / 9.0 m long reach	•	•
Arm: 2.55 m, 3.0 m, 3.35 m, 3.9 m, 4.8 m / 6.0 m long reach	•	•
Linkage with lifting eye	•	•
Service		
Tool kit, daily maintenance	•	•
Tool kit, full scale	•	•

SELECTION OF VOLVO OPTIONAL EQUIPMENT

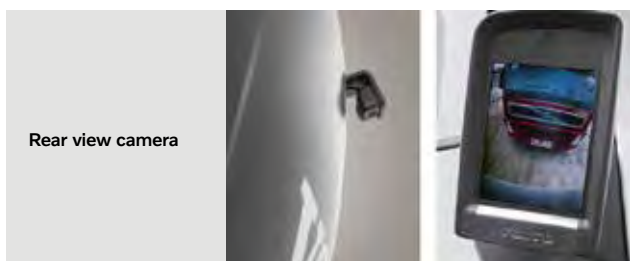
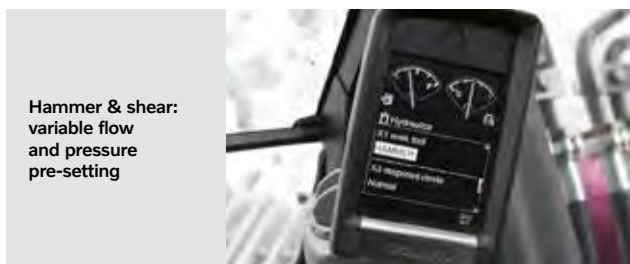
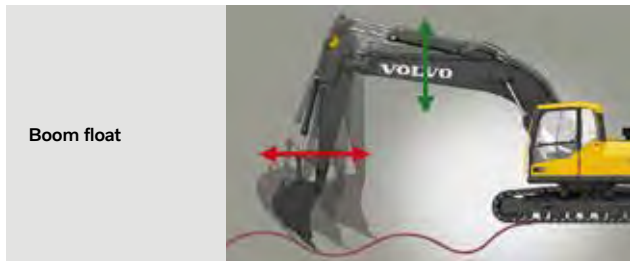



VOLVO

Volvo Construction Equipment
volvoce.com